

1600GS

20-100 HP

inovair[®]
Geared Centrifugal Blowers

HIGHEST DURABILITY

The **Inovair 1600GS** is the most capable, durable and compact blower in its class. Designed with a rugged single-stage gearbox and modern high efficiency aero stages, this proven product is also a direct replacement for aging legacy centrifugal blowers. The **1600GS** is designed, manufactured and serviced in the USA by **Inovair**, the leading supplier of compact geared centrifugal blowers for aircraft GSE, wastewater and industrial applications.

INOVAIR ADVANTAGES

- Highest Reliability
- Best-In-Class Efficiency
- Direct Replacement for Competing Legacy Blowers
- Compact & Flexible Design
- Ideal for Mobile Applications
- Industry-Leading Support
- Designed and Made In The USA

η = Efficiency™

TECHNICAL SPECS

Flow Capacity:	up to 2200 SCFM
Design Pressure:	Up to 8 PSIG
Motor Power:	up to 100 HP
Drive:	50/60 Hz VFD
Operational Temps:	-40°F to 160°F
Impeller:	5-axis machined 7075-T6 Aluminum
Lubrication:	Centrifugally directed oil mist system
Seals:	Aerospace-grade seals
Gearbox:	8.21:1 step-up ratio
Weight:	110 lbs

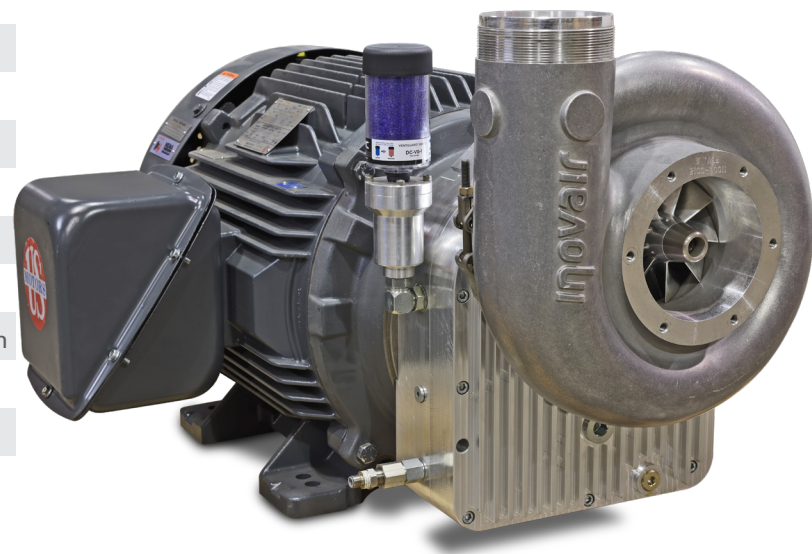
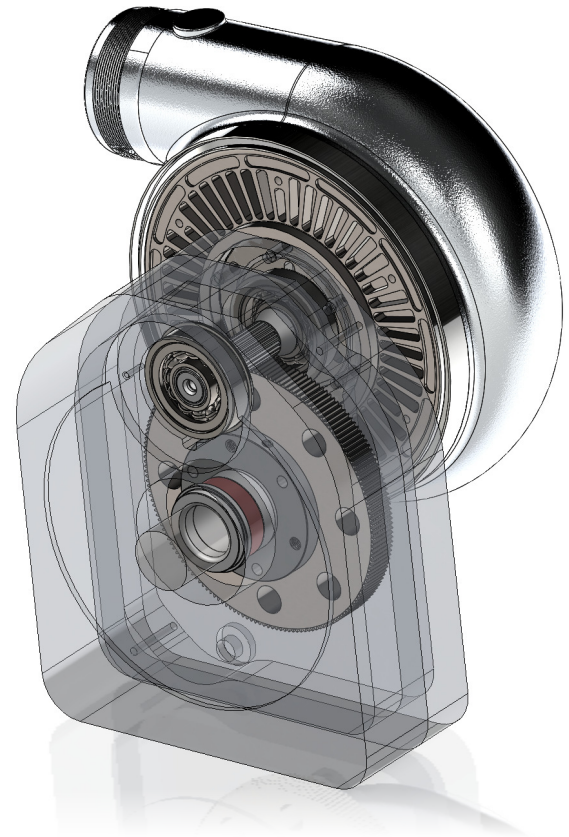

HIGHEST EFFICIENCY AERODYNAMICS

With decades of experience and proven capabilities, **Inovair** is able to deliver best-in-class efficiency and durability for your demanding applications. This high efficiency, thanks to state-of-the-art compressor and gearbox designs, helps optimize both performance and energy consumption. From the impeller blade shapes and volute clearances to the materials and manufacturing processes employed, **Inovair** provides reliable performance matched perfectly and uniquely to each application.

PRODUCT DETAILS

- Direct Replacement for Competing Legacy Centrifugal Blowers
- Highest Efficiency Design
- Volute Discharge May Be Positioned to Horizontal Right or Vertically Up Position for Installation Ease.
- Rugged Single Stage Gearbox With Precision Ground Gearing Assures Smooth Operation With High Mechanical Efficiency and Low Noise Levels.
- State-Of-The-Art Aerospace Carbon-Seal, Oil-Free Air
- Self-Contained Oil Mist Lubrication Does Not Require External Connections
- Proven in High-Demanding Application Across The Globe
- Readily Available Factory Support (parts and service)

GET IN TOUCH WITH INOVAIR

At **Inovair**, we pride ourselves on offering our customers the efficiency and durability they need, with a solution that is simple to maintain and lowers the overall cost of ownership. When you choose **Inovair**, you get the best. Call us today to learn how we can help lower your costs.

SCAN FOR MORE DATA



INDUSTRY-LEADING SUPPORT

Should an issue arise, **Inovair** technical and customer service, located at our headquarters in Kansas City, is ready to assist immediately. Our customers rave about the service **Inovair** provides before, during, and after the installation. Visit our website for testimonials on our superior service.

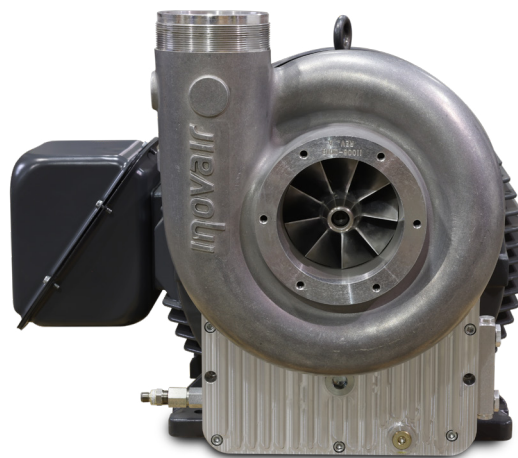

DESIGNED, MANUFACTURED, & SERVICED IN THE USA

When it comes to a supplier's ability to deliver innovation and quality, location matters. **Inovair** is not only headquartered in the heartland of America, but most operations, from engineering to manufacturing to service, are within the same

facility. Our vertical integration means shorter leadtimes for parts and manufacturing. This creates a collaborative environment with lean design, manufacturing, and servicing practices. Also available to purchase factory direct.



08/23

